

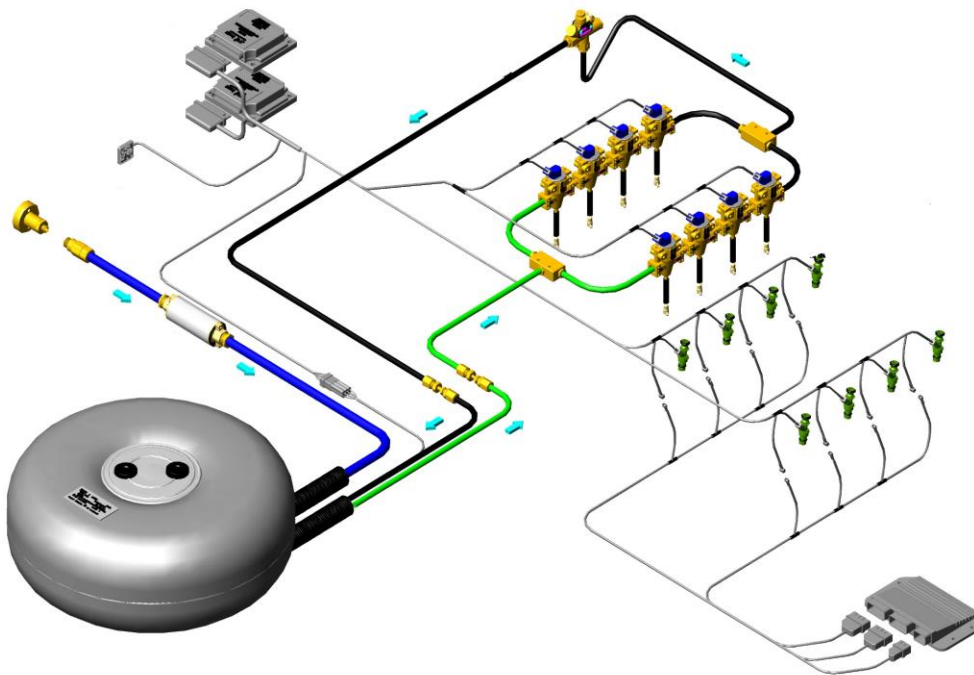

# ICOM PORTABLE VISE - FIELD ATTACHABLE FITTING ASSEMBLY INSTRUCTIONS



**P11X-9209-AB**  
Revision: B - Dated 5/26/17  
Replaces: A - Dated 5/14/12



10) THE FOLLOWING IS A LIST OF EQUIPMENT REQUIRED TO ASSEMBLE THE FIELD ATTACHABLE FITTING ONTO THE ICOM THERMOPLASTIC HOSE:

- LUBRICANT (GREASE)
- 14mm OPEN END WRENCH (2 REQUIRED FOR THE 3/16" HOSE - 1 REQUIRED FOR THE 1/4" HOSE)
- 17mm OPEN END WRENCH (1 REQUIRED FOR THE 1/4" HOSE ONLY)
- 20mm OPEN END WRENCH (3/8" HOSE ONLY)
- 22mm OPEN END WRENCH (3/8" HOSE ONLY)
- PORTABLE HOSE VISE (SPECIFIC TO HOSE SIZE BEING ASSEMBLED)
- APPROPRIATE HOSE CUTTER - DO NOT USE ANYTHING WITH A SERRATED EDGE

**A - ICOM STANDARD THERMOPLASTIC HOSE**

**B - ICOM STEEL BRAIDED THERMOPLASTIC HOSE**

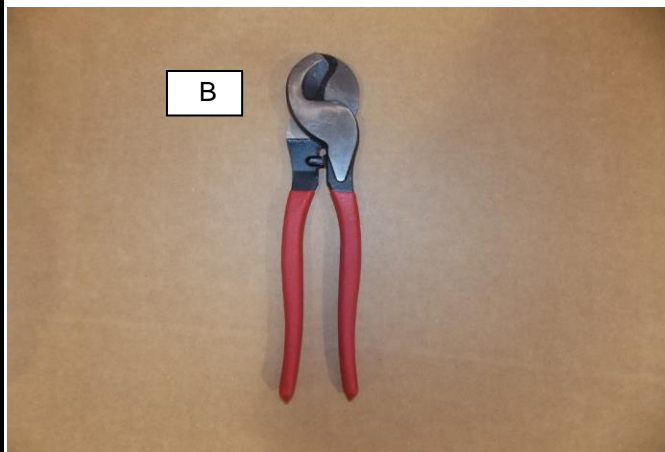
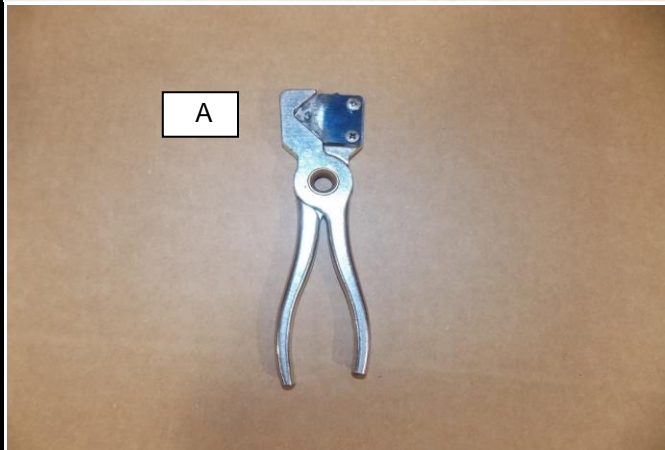

ITEM	PART NUMBER	QTY	DESCRIPTION	TORQUE	TOOLS
	90700010	1	PORTABLE VISE - 3/16" HOSE		PORTABLE VISE
	90700013	1	PORTABLE VISE - 1/4" HOSE		14mm OPEN END WRENCH
	90700012	1	PORTABLE VISE - 3/8" HOSE		17mm OPEN END WRENCH
					20mm OPEN END WRENCH
					22mm OPEN END WRENCH
PROCESS NAME					REV
PORTABLE VISE - FIELD ATTACHABLE FITTING ASSEMBLY INSTRUCTIONS					B
PROCESS NUMBER					PAGE
P11X-9209-AB					1 OF 6

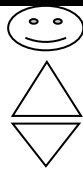

INSPECTION  
 TORQUE  
 CRITICAL PROCESS



ITEM NUMBER



OPERATION

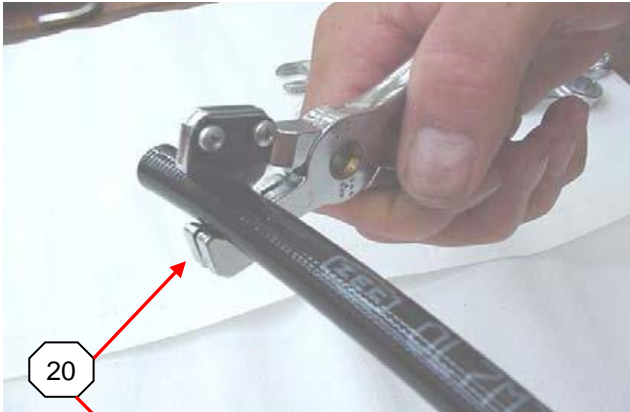

20) USING THE APPROPRIATE HOSE CUTTER, CUT THE END OF THE HOSE TO THE DESIRED LENGTH.

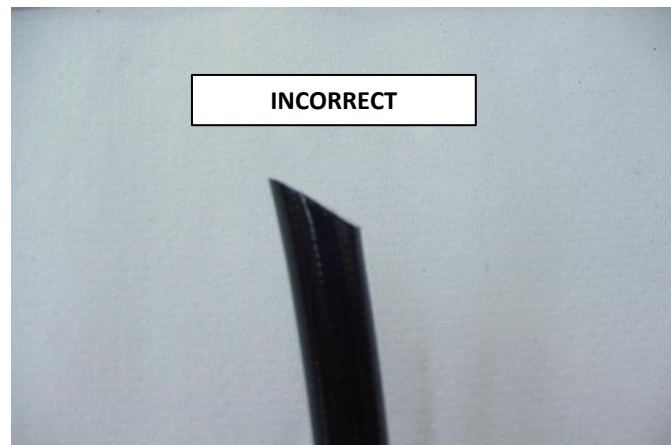
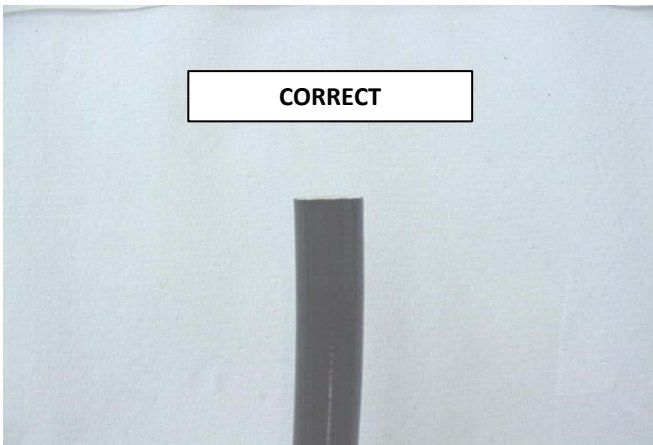

ITEM	PART NUMBER	QTY	DESCRIPTION	TORQUE		TOOLS	
						STANDARD HOSE CUTTER	
						STEEL BRAID HOSE CUTTER	
						PROCESS NAME	REV
						PORTABLE VISE - FIELD ATTACHABLE FITTING	B
						ASSEMBLY INSTRUCTIONS	
						PROCESS NUMBER	PAGE
						P11X-9209-AB	2 OF 6

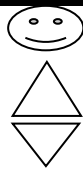

**INSPECTION**  
**TORQUE**  
**CRITICAL PROCESS**



**ITEM NUMBER**



**OPERATION**

**STEEL BRAIDED HOSE ONLY**



25) USING A PAIR OF PLIERS, CAREFULLY REFORM THE END OF THE HOSE BACK TO IT'S ORIGINAL STATE AFTER THE CUT IS MADE.

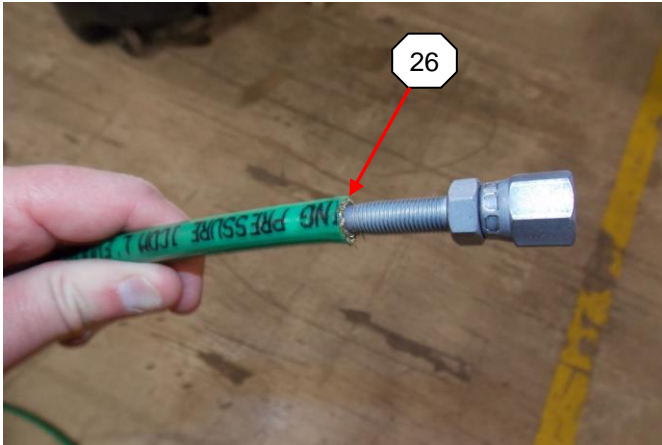

26) OBTAIN A FITTING CORRESPONDING TO THE HOSE SIZE; INSERT THE HOSE END OF THE FITTING INTO THE END OF THE HOSE AS SHOWN TO REFORM THE INTERNAL PORTION OF THE HOSE.

ITEM	PART NUMBER	QTY	DESCRIPTION	TORQUE	TOOLS
REF	390320	1	3/16" FIELD ATTACHABLE STRAIGHT FITTING		PLIERS
REF	390390	1	3/16" FIELD ATTACHABLE 90° FITTING		
REF	390420	1	1/4" FIELD ATTACHABLE STRAIGHT FITTING		
REF	390490	1	1/4" FIELD ATTACHABLE 90° FITTING		
REF	390820	1	3/8" FIELD ATTACHABLE STRAIGHT FITTING		
REF	390890	1	3/8" FIELD ATTACHABLE 90° FITTING		
PROCESS NAME					REV
PORTABLE VISE - FIELD ATTACHABLE FITTING ASSEMBLY INSTRUCTIONS					B
PROCESS NUMBER					PAGE
P11X-9209-AB					3 OF 6



**30)** PLACE HOSE INTO PORTABLE VISE.

EXTEND THE END OF THE HOSE APPROXIMATELY 1-1/2" BEYOND THE END OF THE VISE AS SHOWN.

SECURELY TIGHTEN THE HOSE INTO THE VISE BY ROTATING THE BLACK HANDLE 'CLOCKWISE'.

APPLY A THIN COAT OF LUBRICANT (GREASE) TO THE OUTER HOSE COVER ON THE PORTION OF THE HOSE EXTENDED BEYOND THE END OF THE VISE.

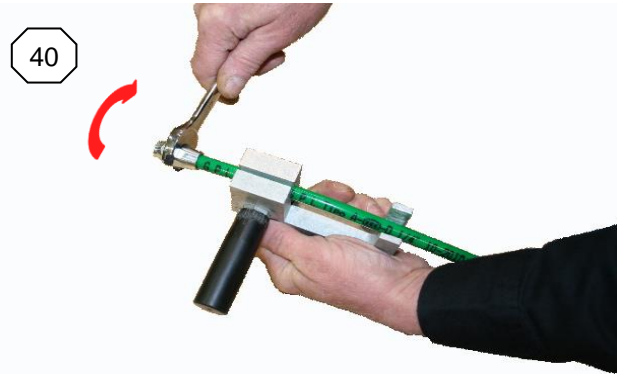

**40)** HANDSTART THE FERRULE 'COUNTER CLOCKWISE' ONTO THE END OF THE HOSE.

CONTINUE INSTALLATION OF THE FERRULE USING AN OPEN END WRENCH. THE INSTALLATION SHOULD BE CONSISTENT WITHOUT EXCESSIVE FORCE.

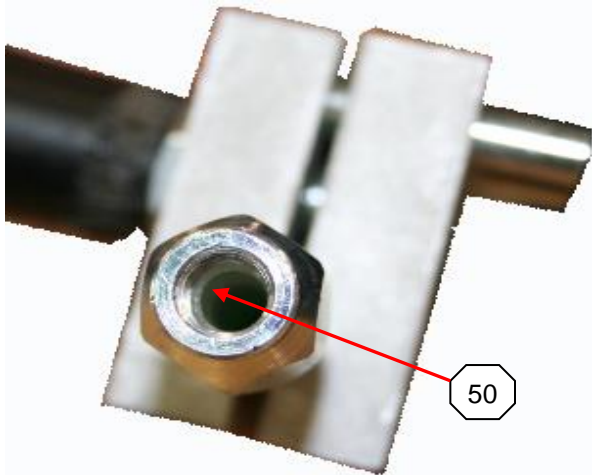

**50)** ROTATE THE FERRULE ONTO THE HOSE UNTIL THE HOSE REACHES THE COUNTERBORING OF THE FERRULE AS SHOWN.

ITEM	PART NUMBER	QTY	DESCRIPTION	TORQUE	TOOLS
REF	390300	1	3/16" HOSE FERRULE		14mm OPEN END WRENCH
REF	391300	1	3/16" HOSE FERRULE (STEEL BRAID)		17mm OPEN END WRENCH
REF	390400	1	1/4" HOSE FERRULE		20mm OPEN END WRENCH
REF	391400	1	1/4" HOSE FERRULE (STEEL BRAID)		22mm OPEN END WRENCH
REF	391800	1	3/8" HOSE FERRULE (STANDARD & STEEL)		
REF	90700010	1	PORTABLE VISE - 3/16" HOSE	<b>PROCESS NAME</b> <b>PORTABLE VISE - FIELD ATTACHABLE FITTING</b> <b>ASSEMBLY INSTRUCTIONS</b>	
REF	90700013	1	PORTABLE VISE - 1/4" HOSE		
REF	90700012	1	PORTABLE VISE - 3/8" HOSE		
				<b>PROCESS NUMBER</b> <b>P11X-9209-AB</b>	<b>REV</b> <b>B</b>
					<b>PAGE</b> <b>4 OF 6</b>

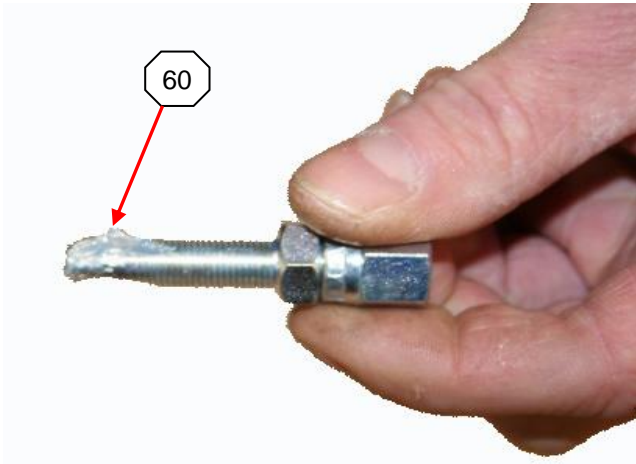

**60)** LUBRICATE THE HOSE END OF THE FITTING WITH A SMALL AMOUNT OF GREASE (STRAIGHT FITTING SHOWN).

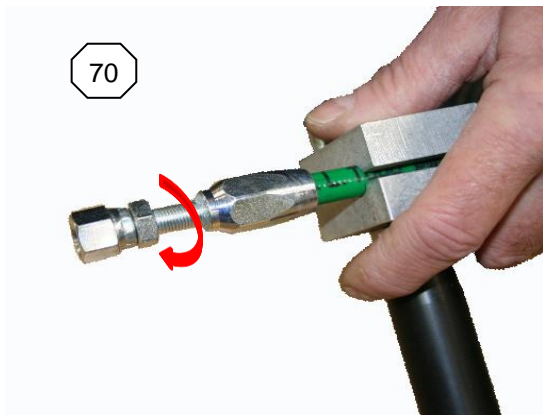

**70)** INSERT AND HANDTIGHTEN FITTING 'CLOCKWISE' INTO THE FERRULE AS SHOWN.

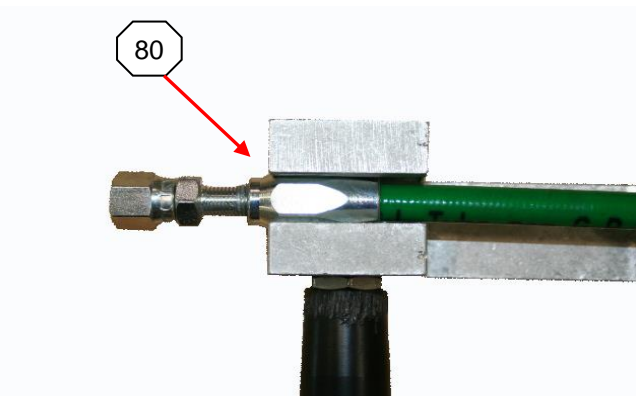

**80)** LOOSEN VISE AND REMOVE HOSE; POSITION AND TIGHTEN FERRULE INTO THE VISE AS SHOWN.

ITEM	PART NUMBER	QTY	DESCRIPTION	TORQUE	TOOLS
REF	390320	1	3/16" FIELD ATTACHABLE STRAIGHT FITTING		PORTABLE VISE
REF	390390	1	3/16" FIELD ATTACHABLE 90° FITTING		LUBRICANT (GREASE)
REF	390420	1	1/4" FIELD ATTACHABLE STRAIGHT FITTING		
REF	390490	1	1/4" FIELD ATTACHABLE 90° FITTING		
REF	390820	1	3/8" FIELD ATTACHABLE STRAIGHT FITTING		
REF	390890	1	3/8" FIELD ATTACHABLE 90° FITTING		
REF	90700010	1	PORTABLE VISE - 3/16" HOSE	<b>PROCESS NAME</b> PORTABLE VISE - FIELD ATTACHABLE FITTING ASSEMBLY INSTRUCTIONS	
REF	90700013	1	PORTABLE VISE - 1/4" HOSE		
REF	90700012	1	PORTABLE VISE - 3/8" HOSE	<b>PROCESS NUMBER</b> P11X-9209-AB	
					<b>REV</b> <b>B</b>
					<b>PAGE</b> 5 OF 6

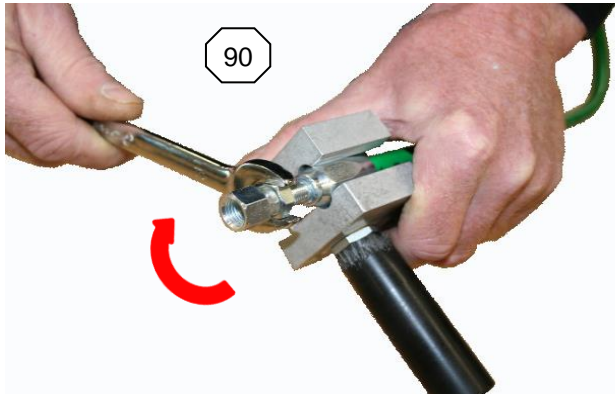

**90)** CONTINUE TO TIGHTEN FITTING 'CLOCKWISE' INTO THE FERRULE WITH AN OPEN END WRENCH AS SHOWN.

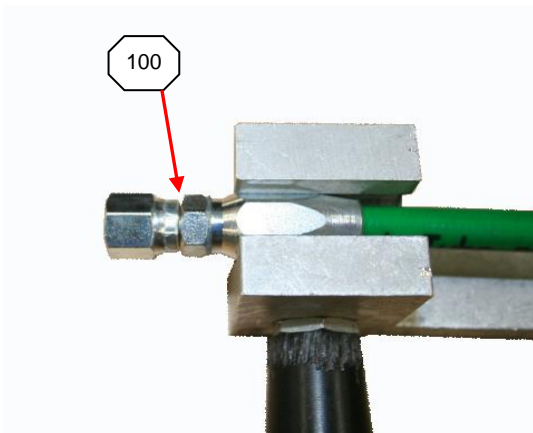

**100)** TIGHTEN THE FITTING UNTIL THE FERRULE AND FITTING ARE FULLY SEATED TOGETHER AS SHOWN.

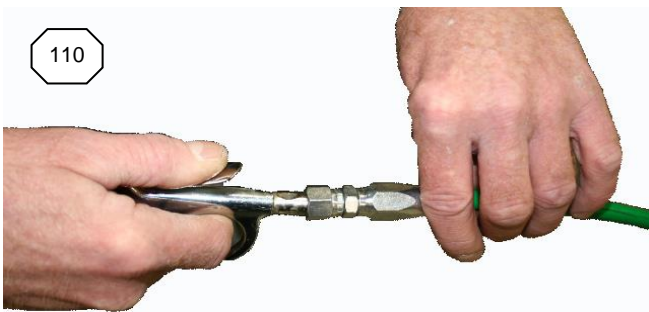

**110)** LOOSEN VISE AND REMOVE HOSE.

INSERT AIR INTO THE HOSE TO VERIFY NO OBSTRUCTIONS OCCURRED DURING ASSEMBLY.

THE ASSEMBLY IS COMPLETE.

ITEM	PART NUMBER	QTY	DESCRIPTION	TORQUE	TOOLS
REF	390320	1	3/16" FIELD ATTACHABLE STRAIGHT FITTING		PORTABLE VISE
REF	390390	1	3/16" FIELD ATTACHABLE 90° FITTING		14mm OPEN END WRENCH
REF	390420	1	1/4" FIELD ATTACHABLE STRAIGHT FITTING		17mm OPEN END WRENCH
REF	390490	1	1/4" FIELD ATTACHABLE 90° FITTING		20mm OPEN END WRENCH
REF	390820	1	3/8" FIELD ATTACHABLE STRAIGHT FITTING		22mm OPEN END WRENCH
REF	390890	1	3/8" FIELD ATTACHABLE 90° FITTING		
REF	90700010	1	PORTABLE VISE - 3/16" HOSE	<b>PROCESS NAME</b> <b>PORTABLE VISE - FIELD ATTACHABLE FITTING ASSEMBLY INSTRUCTIONS</b>	
REF	90700013	1	PORTABLE VISE - 1/4" HOSE		
REF	90700012	1	PORTABLE VISE - 3/8" HOSE	<b>PROCESS NUMBER</b> <b>P11X-9209-AB</b>	
					<b>REV</b> <b>B</b>
					<b>PAGE</b> <b>6 OF 6</b>